

Isometrische Ansicht
Maßstab: 1:2

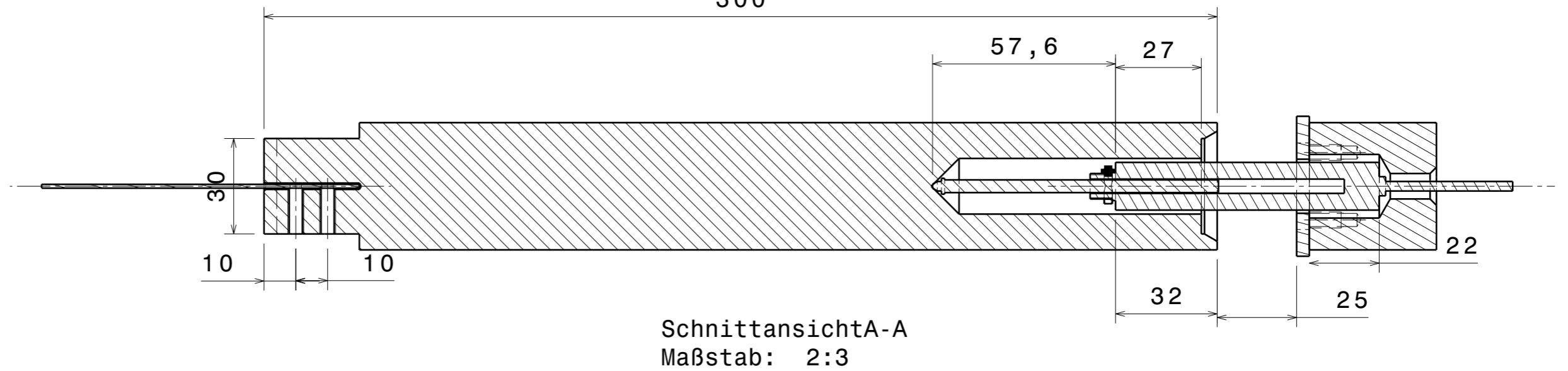

Schnittansicht A-A
Maßstab: 2:3

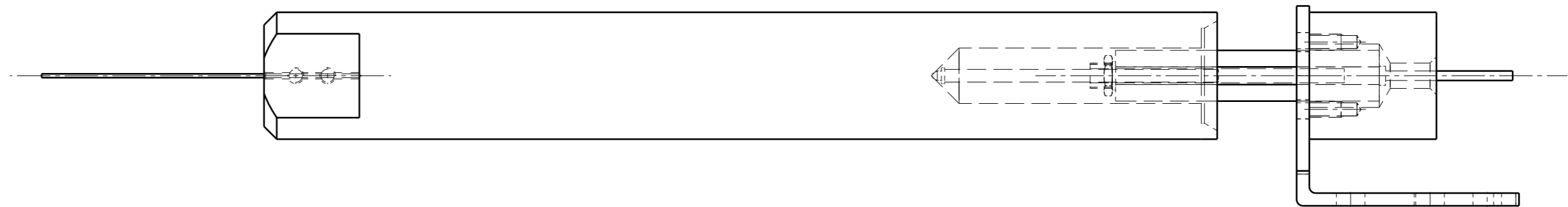

Hilfsansicht B
Maßstab: 2:3

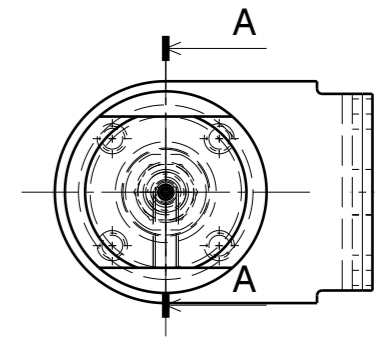

Verwendbar fuer Auftrags-Nr.		Tolerierung/Tolerancing ISO 8015 Ⓔ = Hüllbedingung Envelope Requirement		PositionControl GmbH	
Mod	CAD3D+ Zeichnung	ISO 128	ISO 2768-mH	Massstab/Scale 1:1	Masse Weight 0,0 kg
			Werkstueckkanten Edges of Work.Parts ISO 13715	Werkstoff/Material	Werkstoff/Material-No.
			Oberflaeche/Surface ISO 1302	Edelstahl	1.4301
			Datum	Name	
			Bearb. 05.07.2017	Lang	
			Gepr.		
			Norm		
			Abt.		
			Teile/Part Ident-Nr.		Sachschlüssel-Nr./Classification-No.
			Zeichnungs-Ident-Nr./Drawing-Ident-No.		F Blatt
			-----		3 01
					01 Bl.
Zust.	Aenderung/Revision	Datum	Name	Urspr.	Ers.f. Ers.d.